



**GLIDING NEW ZEALAND INCORPORATED**

***ADVISORY CIRCULAR***  
***AC 3-02***

**AERO TOW Ropes**

**This is an uncontrolled document when printed**

---

© **COPYRIGHT 2016 GLIDING NEW ZEALAND Inc.** No part of this Advisory Circular may be used or reproduced in any form by photocopying or otherwise, or incorporated into any information retrieval system without the written consent of the President of Gliding New Zealand Inc.

## 1 Introduction

This Advisory Circular provides guidance on making up glider aero tow rope assemblies, in particular:

- Rope specification
- The requirements for a weak-link.
- How to make up ropes from bulk roll.
- Rope splicing.
- Care of ropes.
- Towing ring specifications.

## 2 Rope Specification

All rope types lose strength over time due to UV light, abrasion and general wear. Suitable rope materials are 8 mm UV-stabilised polyester, polypropylene or polyethylene – these have about the right elasticity to give a smooth ride to the glider without excessive stretch. Nylon or wire must not be used. *Note that all synthetic ropes must be made from UV-stabilised material.* This is particularly critical for polypropylene and polyethylene ropes as both of these materials have virtually no UV resistance without stabiliser. Cheap ropes of poor quality (readily available from some hardware stores) must be avoided. Specialist suppliers, such as Bridon, are recommended.

### 2 Weak-Link<sup>§</sup>

2.1 Glider Flight Manuals specify a maximum tow line strength, typically 500 to 900 kg<sub>f</sub> depending on glider mass. A minimum tow line strength does not have to be specified, although some glider manufacturers do provide a recommendation. In practice, it is convenient and safe for ropes to incorporate a weak-link of between 300 kg<sub>f</sub> and 500 kg<sub>f</sub> (300 to 500 daN) nominal strength at the tow aircraft end, as follows:

2.2 The weak link should be chosen to provide protection to the towing aircraft, reflecting its take-off mass, for example:

EuroFox, FK9, Aerospool Dynamic	300 kg <sub>f</sub>	TOST <b>green</b> link
Piper Cub	400 kg <sub>f</sub>	TOST <b>yellow</b> link
Piper Pawnee	500 kg <sub>f</sub>	TOST <b>white</b> link.

2.3 See Appendix 1 for towing-ring requirements and Appendix 2 for a typical weak-link assembly.

## 3 Making up Tow Ropes from Bulk Roll

3.1 The recommended minimum length for an aero tow rope is 50m ring to ring. When new, rope lengths should be at least 55m from ring to ring, which allows for re-splicing several times without being reduced to less than 50m. By the time this has been carried out a number of times, and the rope is down to its minimum recommended length, the whole rope is usually well weather-beaten and showing distinct need of retirement. This is typically about 12 months for a club doing around 1,500 tows a year on a grassed airfield.

---

<sup>§</sup> Note that CAR Part 91.709(c)(2) refers to Appendix A.26, which specifies glider tow lines. However, the Director has granted an exemption to this rule in recognition of the fact that it does not reflect best International practice. Reference Exemption 16/EXE/34, attached as Appendix 3.

- 3.2 The temptation to get five rope lengths out of say a 250m roll should be avoided, as some or all of them will all end up too short. As about 200mm is used for each splice, nearly half a metre is used in the splices, so 55.5m is required per rope. Four ropes therefore need 222m. The remaining 28m can be used for ground towing ropes or tie-downs, or each rope can be made a bit longer than 55m.
- 3.3 Tow rings must conform to the specifications given in Appendix 1. The standard single tow rope assembly consists of rope, spliced at the glider end to ring B of a standard tow ring pair, with the weak-link at the other end using one shackle between the weak-link and ring B of a standard tow ring pair, and a rope splice to another shackle on the other end of the weak-link – see Appendix 2.
- 3.4 In years gone by, plastic funnels were sometimes used at the glider end of the rope. This has caused at least one fatal accident – therefore, such funnels must not be incorporated.
- 3.5 Thimbles may be incorporated when the rope is to be used over soft grass. Hard ground or sealed runways will cause excessive wear, so thimbles should not be incorporated in such circumstances.

## 4 Rope Splicing

- 4.1 Ropes are to be spliced at each end for the attachment of towing rings and weak-link shackles. \*\* Splices should have a minimum of five full tucks. Splices are not to be whipped and must remain open for inspection.
- 4.2 Splices may be tapered by using several tapering tucks at the end. This makes a very neat job and eases the abrupt ending of the splice. However, experience has shown that it is almost always the wear at the rings which prompts the re-splicing of the rope, so tapering is merely a ‘nice to have’.
- 4.3 Splices anywhere along the length of the rope are permissible, providing the rope is in good condition. The inline splice should be made with at least four tucks in each direction.
- 4.4 Each splice makes the rope a little heavier and stiffer, so it is recommended that no more than two in-line splices be allowed.

## 5 Rope Assemblies for Double Towing

- 5.1 For “double” towing, two separate ropes are to be used, each with a weak link (as specified in paragraph 2.2 above). These consist of a “short rope” of not less than 50m between rings, and a “long rope” of not less than 80m between rings.

*Note: A “long rope” of about 50m longer than the “short rope” is recommended to provide increased separation between the gliders.*

- 5.2 The “long rope” consists of rope, spliced at the glider end to ring B of a standard tow ring pair, with a weak-link at the other end between the rope and ring B of a double-tow double-ring assembly (see Appendix 1 para 3.3).
- 5.3 The “short rope” consists of rope, spliced at the glider end to ring B of a standard tow ring pair, with a weak-link at the other end between the rope and ring C of a double-tow triple-ring assembly (see Appendix 1 para 3.4).

---

\*\* If operational circumstances require a quick temporary repair, a bowline knot may be used. However, this should be replaced by a splice at the earliest opportunity, as knots are not as strong and abrade more quickly than splices.

5.4 The two ropes are coupled together at the tow plane hook via the multiple rings in such a manner that if jettisoned by the tow pilot, they will automatically separate. This is accomplished by fitting the double-tow *double-ring* assembly over the double-tow *triple-ring* assembly, and then offering the last ring A of the triple-ring assembly up to the tow plane release in the normal manner. The double-ring assembly will be captured on the triple-ring assembly until released.

## 6 Care of Tow Ropes

- (a) Uncoil and coil correctly. Always coil clockwise.
- (b) Watch for kinks that will distort the rope.
- (c) Avoid sharp objects that will severely abrade the surface.
- (d) Ensure that splices are correctly made.
- (e) Avoid very hot surfaces.
- (f) Avoid any overloading that produces permanent set.
- (g) Inspect the full length of rope each morning before using, for possible damage, wear, fraying etc.
- (h) Carefully check well-worn ropes to see if they should be replaced.
- (i) If continually used in a dusty environment, wash the rope periodically.
- (j) Do not leave ropes out in the sun unnecessarily, as this hastens UV degradation.

## Appendix 1      Towing-Rings

### 1.      General

Towing-rings used for the launching of gliders and powered gliders by aero tow, auto tow, or winch, must conform to the specifications below, or be manufactured by TOST GmbH, as detailed in Para 5 below.

### 2.      Ring Sizes

There are three sizes of ring. The specifications are detailed in para 4. These rings are identified as being:

- (a)    Ring A            Standard small ring.
- (b)    Ring B            Standard large ring.
- (c)    Ring C            Special large ring.

### 3.      Ring Assemblies

3.1    There are three types of ring assembly.

- (a)    Standard tow ring assembly.
- (b)    Multiple tow double-ring assembly.
- (c)    Multiple tow triple-ring assembly.

These ring sets are assembled in the following manner.

**Note:** *In all cases the release end is to the left in the following diagrammes, with the rope to the right.*

3.2    Standard towing-ring assembly:      Ring A, Ring B.

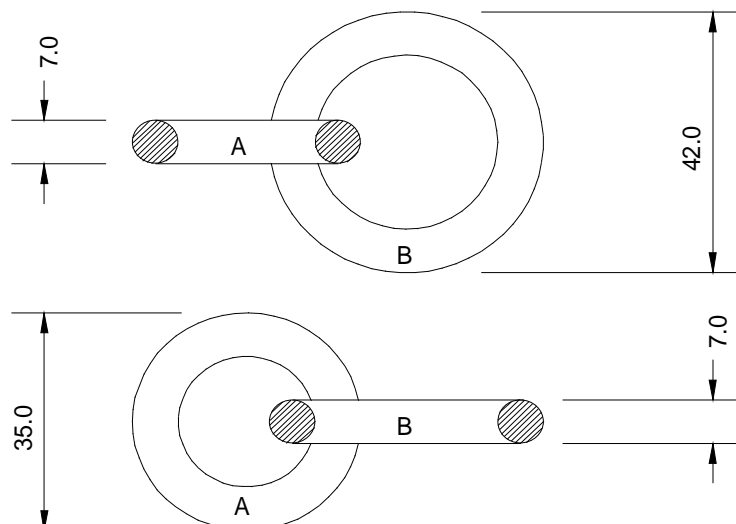

3.3 Double-tow double-ring assembly: Ring C, Ring B.

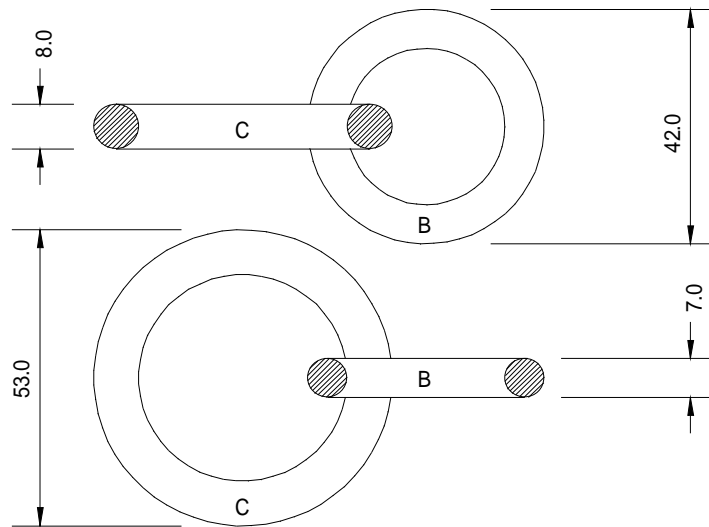

3.4 Double-tow triple-ring assembly: Ring A, Ring A, Ring C.

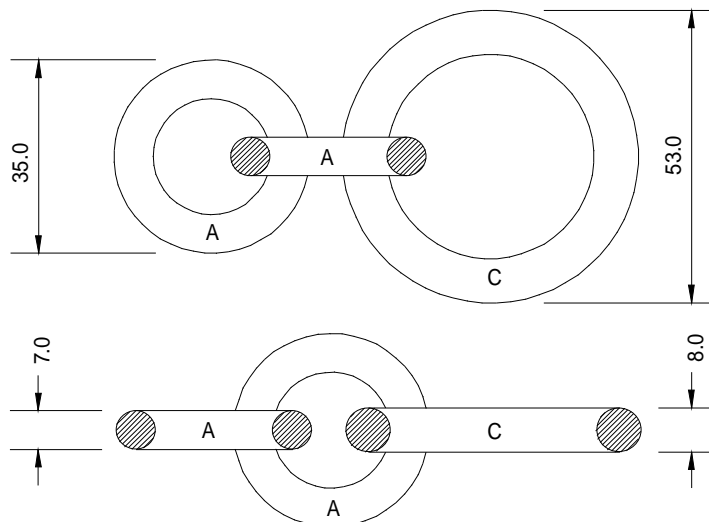

**4 GNZ Specifications**

4.1 Rings are to be manufactured from round section hard drawn wire to the following Specs:

- (a) Wire diameter (Ring A & B) 7mm + 0, - 0.3
- (b) Wire Diameter (Ring C only) 8mm + or - 0.3
- (c) Material spec (All Rings) ANS/NZS 4671 Grade 500 or equivalent.

4.2 Rings are to be circular in shape and cold formed around a mandrel to achieve the following dimensions after welding:

- (a) Standard small ring (ring A) OD = 35mm, + 0, - 0.3  
ID = 21mm, + 0, - 0.3
- (b) Standard large ring (ring B) OD = 42mm, + 0, - 0.5  
ID = 28mm, + 0, - 0.5
- (c) Special large ring (ring C) OD = 53mm, + 0, - 0.5  
ID = 37mm, + 0, - 0.5

4.3 After forming, and cutting into single rings, the ring should be pressed so that the ends are aligned. The cut ends are to be ground at an angle of approximately 45 degrees, from each side to just less than half thickness, (ie. grind to be in the shape of a "J"). The cut ends are to be welded, using MIG or TIG welding methods and techniques, with appropriate electrodes.

4.4 The small ring is made separately, and the large ring joined to it before the large ring is welded.

*Note: During welding care should be taken not to cause heat build-up in the ring, causing it to lose strength.*

4.5 Excess weld is to be ground off. The maximum deformity at the weld to be + or - 0.3mm.

4.6 Final treatment.

(a) Rings are to be passivated.

(b) Finished rings may be plated for preservation during storage.

4.7 Identification. Any form of ID, or other information required, may be stamped or embossed ONLY on the standard large ring.

## 5 TOST Rings

Ring pairs manufactured by TOST GmbH, Part No 102000, can be used in lieu of the standard towing-ring assembly specified in 3.2 above.

## Appendix 2 Typical Aero Tow Weak-Link Assembly

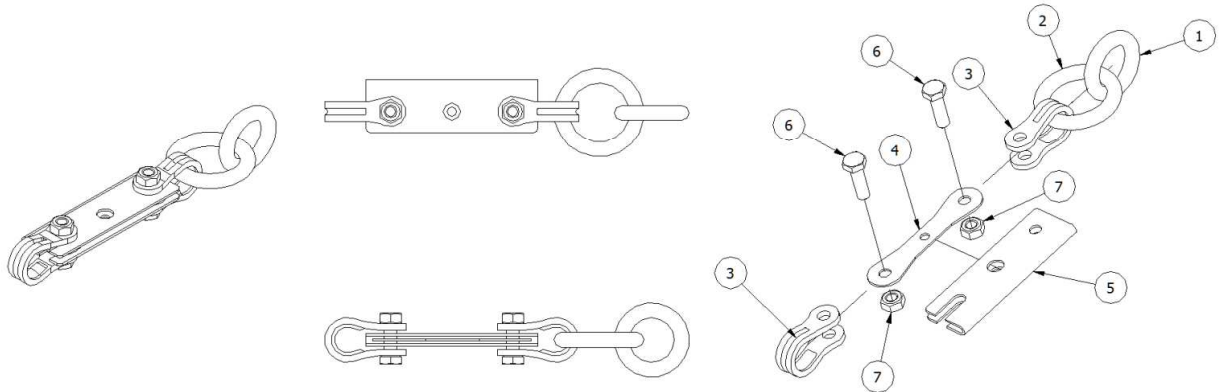

PARTS LIST			
ITEM	QTY	PART NUMBER	DESCRIPTION
1	1	GNZ Tow ring A	Standard GNZ tow ring assembly or Tost ring pair Part No 102000
2	1	GNZ Tow ring B	
3	2	Tost Part No 112600	6 mm weak-link shackle
4	1	Tost Part No 110105	White 500 daN weak-link
5	1	Tost Part No 111000	Protector sleeve for weak-link
6	2	ISO 4017 – M6 x 20	SS hexagon-head screw
7	2	ISO 4032 – M6	SS hexagon Nyloc nut





**FROM—**

the requirement in CAR 91.709(c)(2) that a person must not operate an aircraft to tow a glider in flight unless the towline to be used meets the requirements of Appendix A.26,

**PROVIDED THAT—**

(a) a glider towline, or tow-system incorporating a towline and safety weak link(s), shall have a –

(i) maximum breaking strength of no more than the lesser of the maximum load specified for the towline attachment in the limitations of the tow aircraft and the glider being towed; and

(ii) minimum breaking strength of no less than the higher of the minimum load specified for the towline attachment in the limitations of the tow aircraft and the glider being towed.

(b) Where the limitations of the tow aircraft and glider determined in (a) above are incompatible, a person operating an aircraft towing a glider of not more than 800kg MCTOW may disregard any minimum towline strength specified in the respective flight manuals, provided that the tow system safety weak link breaking strength is no less than 300daN.

(c) Should a conflict occur between the maximum and minimum values determined in (a) and (b) above, then the lesser of the two values is to be used to determine the breaking strength of the safety weak link.

(d) Where a single safety weak link is incorporated in the tow system; the safety weak link shall be installed at the tow aircraft end of the tow line.

This exemption shall remain in effect unless withdrawn in writing by the Director.

**SIGNED** at Wellington )

this 11<sup>th</sup> day of July 2016 )

by **John Kay** )

Acting Director Civil Aviation )



---