



**GLIDING NEW ZEALAND INCORPORATED**

***ADVISORY CIRCULAR***  
***AC 3-18***

**GLIDER WEIGHT AND BALANCE**

**This is an uncontrolled document when printed.**

---

© **COPYRIGHT 2021 GLIDING NEW ZEALAND Inc.** No part of this Advisory Circular may be used or reproduced in any form by photocopying or otherwise, or incorporated into any information retrieval system without the written consent of the President of Gliding New Zealand Inc.

## **1.0 Introduction**

- 1.1 The weight and balance of parts of a glider, as well as the glider itself, are important for both safe and efficient operation.
- 1.2 Considering the glider as a whole, if the centre of gravity (CG) was aft of the aft limit as determined by the manufacturer, stability would be reduced and spin recovery could be delayed or even prevented. If the CG was forward of the forward limit, even full back elevator may not slow the aircraft down sufficiently for a safe landing.
- 1.3 Maintenance of the CG of a glider within the specified limits is complicated because the (front) pilot sits well forward of the CG and has a significant impact on the in-flight CG position. Gliders flown by a number of different pilots need to take this into account.
- 1.4 Even when the CG is within the allowable range, if the CG is towards the aft limit the glider will fly slower with less stick back pressure and/or back trim, and therefore climb better in weak lift. However, it will also be less stable, and require more frequent control inputs. If the CG is towards the forward limit the pilot may find it hard to sense thermals and weak lift, and the aircraft will feel less sensitive.
- 1.5 Some manufacturers place weight limits on individual parts of a glider. These limits would be detailed in the Maintenance Manual (MM) for the aircraft. They become important when repair or repainting work is undertaken, because this may add additional weight.
- 1.6 Gliders are normally weighed empty, and a calculation performed to determine the minimum and maximum pilot weights allowable in the cockpit to keep the CG within its allowable range in flight. This is often done too conservatively, with the result that nose ballast is added to gliders to lower the minimum cockpit load to, say, 70 kg - but the usual pilot with parachute is over 90 kg.

## **2.0 Maintenance Requirements**

- 2.1 A glider needs to be weighed and a weight-and-balance calculation performed whenever a significant change in the weight or balance is suspected by the inspecting engineer. The addition or removal of significant equipment, or repair or refinishing, would normally require a reweigh.

## **3.0 Weighing Equipment**

- 3.1 For a glider, a scale is required for the main wheel and the tail wheel/skid. Low profile scales are preferred because it is easier to manoeuvre the glider on and off without damage. Scales incorporating electronic load cells are more stable than older, mechanical scales.
- 3.2 Scales need to be calibrated within the preceding 12 months. CAA AC 43-2 specifies the accuracy required, being  $\pm 0.2\%$  of the applied load or  $\pm 2.0$  kg, whichever is the greater. Requirements for calibration are contained in CAA AC 43-13.
- 3.3 A tolerance of  $\pm 2.0$ kg at the tail is quite significant when weighing gliders. A greater level of accuracy would be preferred. A tolerance of better than 0.5 kg is suggested.

- 3.4 A proven design for a low-profile main wheel platform scale capable of weighing a heavy 2-seat glider (ASH-25 with 2 persons on board) is available from the NAO for those wishing to fabricate such a scale. It uses 3 load cells of 250 kg capacity.
- 3.5 For the tail, an industrial platform scale of 50 kg or 100 kg capacity is adequate. A system of packing or jacking the tail scale is required to bring the aircraft to the flying position as detailed in the aircraft's Maintenance Manual.

#### 4.0 Measurement of Arms

- 4.1 Engineers should be thoroughly familiar with the principle of Moments. This can be summarised by the expression that, for a glider at rest, the sum of the Moments about any datum point is equal to the weight of the glider (G) acting through the "centre of gravity".

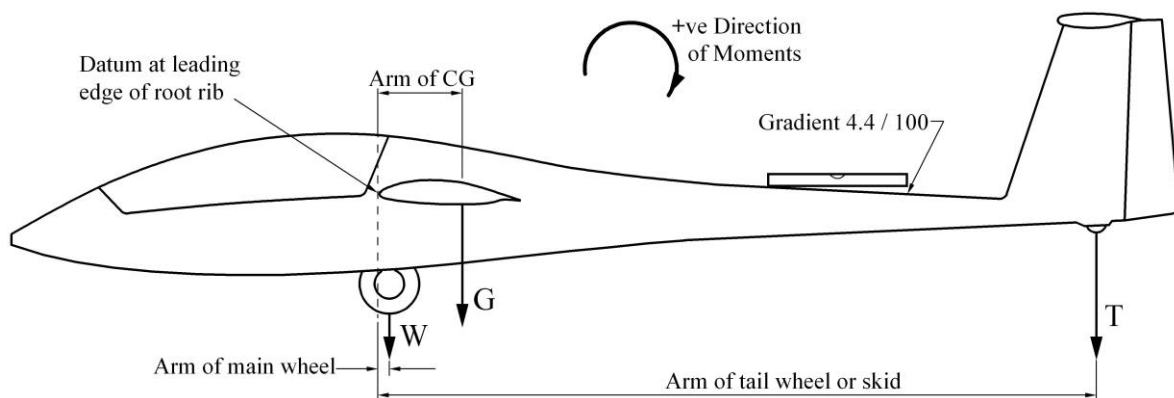

- 4.2 The point from which measurements are taken is called the datum. The location is specified in the glider MM, and is the point from which the CG Arm is measured. A common datum in gliders is the leading edge of the root rib, but manufacturers do use other datums.
- 4.3 The tail of the glider must be raised until the aircraft is in the in-flight pitch attitude. The MM will specify this attitude for each glider, normally by specifying the gradient of a straight section on the top or bottom of the aft section of the fuselage. The glider needs to be in this position with wings level for both measurement and weighing.
- 4.4 Measurement of the Arms is much easier to do before the aircraft is put on the scales. Use plumb bobs to transfer the location of each measurement point from the glider onto the hangar floor. A plumb bob can be suspended from the leading edge of the root rib on each side of the glider, and points marked on the floor. Then draw a line to connect these points.
- 4.5 Drop a plumb line from the centre of the axle for a wheel. With a tail skid place a piece of round bar or angle transversely under the skid so the Arm can be accurately determined.
- 4.6 The two required measurements are the Arm from datum to main wheel, and the Arm from datum to tail wheel (or skid measuring point). All measurements should be taken from the datum, and be to the nearest millimetre, expressed in metres (eg 4.245m). If aft is positive and the glider rests on its nose wheel, the Arm will be negative if forward of the datum.

- 4.7 Some manuals and forms use the distance between the main wheel and tail wheel. This is confusing because Moments are being taken about the main wheel, not the datum. It is good practice to understand each calculation as it is made, and not blindly follow a formula.

## **5.0 Weighing the Empty Glider**

- 5.1 The glider needs to be prepared for weighing. There needs to be a clear list of what is included the glider when it is weighed. This list forms part of the empty weight report.
- 5.2 In general, parachutes and drink bottles are not included, as these are associated with the pilot. Otherwise the glider is in normal flight configuration. Check that all batteries are installed (including tail batteries if used). Include pickets, first aid kit and oxygen cylinder. Dump all water ballast. For motor gliders, drain all fuel except the unusable amount. Retractable engines stay retracted. Canopy is closed. Check the specific MM for further details. Write down a list of all "removable" items that were in the glider at the time of weighing, including navigation displays that are not bolted into the panel.
- 5.3 Move the flight-configured glider onto the scales. Adjust the tail attitude to the required gradient. Level the wings, and ask the person on the wingtip to let the glider balance so that the entire weight is on the two scales. This is best in a hangar sheltered from wind gusts.
- 5.4 Wait for the scales to stabilise then write down the main and tail readings. These weights and moment arms will form the basis for the empty weight report.

## **6.0 Weighing the Glider with Pilot**

- 6.1 For privately-owned gliders with a single pilot it is optional but very useful to weigh with pilot and parachute included. This enables an accurate determination of the in-flight CG position without estimating the arm of the pilot or relying on manufacturer data. Different seat cushion thicknesses or seat back adjustments can change the pilot moment.
- 6.2 If you have a spreadsheet set up you can now determine the exact in-flight CG. This can be expressed as the percentage of the CG range from either the forward or the aft limit. For pleasant and sensitive handling a position 25-35% forward of the aft limit is a good starting point, although different gliders have their own sweet spots.
- 6.3 If ballast is added or removed at this stage, in order to tune the CG position, the glider would need to be reweighed in its empty configuration for the empty weight report.
- 6.4 Some pilots extend this exercise to weigh with water ballast as well as the pilot, to optimise the CG position under competition conditions.

## **7.0 Calculations**

- 7.1 Moment calculations in glider log books frequently contain errors. Units must be consistent. It is best to stick to kilograms and metres. Most people develop a spreadsheet, which makes the calculations easy to be check for accuracy.

7.2 Taking the datum as the leading edge of the root rib, the tail-down moment about datum is:  
 $W * \text{main wheel arm} + T * \text{tail wheel arm} = \text{tail-down Moment}$  (units: kg-m)

7.3 The position of the CG (aft of the datum) is:  
 $\text{Arm of CG} = \text{tail-down moment} / \text{empty weight of glider}$  (units: metres)

### Weight and Balance Calculation for Glider

Report Reference MC/GCK/W10  
 Date+Place of Weighing 7 Nov 2010 at Paraparaumu  
 Type + Registration Schempp Hirth Ventus 2cT ZK-GCK  
 Scale Operator Martyn Cook

*insert* *calculates* *iterate*

**WEIGHT** **ARM** **MOMENT**  
 aft of datum tail-down  
**kg** **metres** **kg-m**

<i>Enter Data from Manual</i>	Maximum All-up Weight, MAUW	525.0		
	Maximum Water Ballast Capacity	174.0		
	Maximum Forward CG position		0.250	
	Maximum Aft CG position		0.380	
	Main Wheel Distance Aft of Datum, M		0.106	
	Tail Wheel Distance Aft of Datum		4.245	
	Distance Between Main and Tail, L		4.139	

<b>Aircraft Empty</b>	Weight on Main Wheel = W	300.5		
	Weight on Tail Wheel = T	38.8		
	Total Empty Weight = G	339.3		
	Moment about Datum			196.35
	Arm of CG about Datum		0.579	

<b>Aircraft + Pilot</b>	Weight on Main Wheel = M	412.0		
	Weight on Tail Wheel = T	23.9		
	Total Loaded Weight	435.9		
	Moment about Datum			145.13
	Arm of CG about Datum		0.333	
	Percentage of range forward from aft limit	36.2%		

<b>Minimum Cockpit Load</b>	Pilot Weight and Moment (calculated)	96.7		-51.22
	Arm of Pilot (calculated)		-0.530	
<i>to find min cockpit load</i>	Min cockpit load in front seat (iterate)	74.1		-39.27
<i>iterate red box until</i>	Total empty aircraft plus min weight pilot	413.4	0.380	157.08
<i>this line result = 0%</i>	Percentage of range forward from aft limit	0.0%		

This sample spreadsheet is available from the NAO, or write your own.

7.4 Minimum Cockpit Load: This is the minimum weight of pilot plus parachute (if applicable) which would bring the CG forward of the aft limit. The complicated part of this calculation is that changes in pilot weight changes both the total weight and the moment.

- 7.5 It is easy to determine the Minimum Cockpit Load by iteration, using a spreadsheet:  
Empty Moment - (Pilot Wt \* Pilot Arm) = (Empty Wt + Pilot Wt) \* Arm of aft CG
- 7.6 Maintenance Manuals generally use a graphical method to determine the minimum cockpit load, given the Weight of the glider and the Arm of the CG.
- 7.7 The minimum and maximum cockpit loads need to be clearly placarded in the glider.

## **8.0 Other Weights Limitations**

- 8.1 Some gliders have other weight limitations. These include:
- maximum weight on seat (includes pilot and parachute, typically 110 kg)
  - maximum weight of all non-lifting parts
  - maximum all-up weight (MAUW), which includes water ballast, fuel, pilot(s), etc

## **9.0 Documentation in Log Book and Flight Manual**

- 9.1 There are two CAA Forms which are used to record weighing. Both need to be completed:
- CAA Form 2102 Aircraft Weight and Balance Report, which is placed in the Log Book
  - CAA Form 2173 Weight and Balance Data, which is carried in the glider
- 9.2 Use of the calculation box on Page 2 of Form 2012 may be regarded as optional for gliders because of its confusing nature.
- 9.3 Form 2102: The following is the minimum information that should be recorded:
- Datum Reference (means the location of the datum)
  - Weight on Main Wheel
  - Weight on Tail Wheel or Skid
  - Total Empty Weight
  - Distance to Empty Weight CG (Forward or Aft of Datum)
  - Empty Weight Moment about Datum
- 9.4 Form 2173: There are copies of this form on the CAA web site which have fillable fields, so a neatly-typed document can be produced. The minimum that should be recorded is:
- Total Empty Weight
  - Datum Reference
  - Longitudinal Distance to Empty Weight CG (Forward or Aft of Datum)
  - Empty Weight Moment about Datum
- 9.5 If a spreadsheet has been used to record all measurements and calculations, a signed and dated copy should be included with the maintenance records.

## 10.0 Adding or Removing Items

10.1 When an item is added or removed from a glider, it affects two things:

- total weight
- arm of CG (unless the item is exactly on the CG)

10.2 It is possible to calculate the new in-flight CG position for any adjustment. It is important to take moments consistently about the datum, rather than some other position.

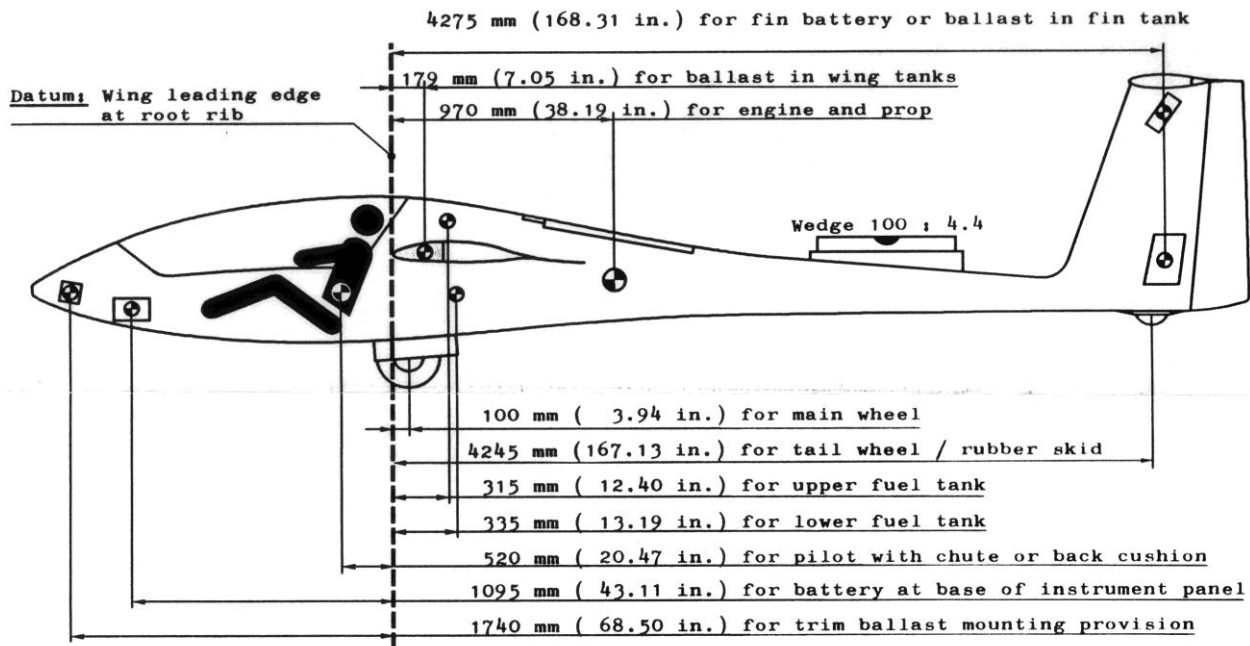

10.3 Worked example 1: In the aircraft above, calculate the change of in-flight CG due to a reduction in pilot weight of 10.0 kg, which is to be compensated for by adding 3.0 kg at the nose trim ballast location.

Working: Refer to the spreadsheet below. Start with the in-flight Weight and Moment. Add the changes in Weight and Moment. Note the +/- sign convention in all columns.

<i>tail-down is positive for Arm, Moment</i>	<b>WEIGHT</b> <i>kg</i>	<b>ARM</b> <i>m</i>	<b>MOMENT</b> <i>kg-m</i>
Total Weight and Moment	435.9		145.13
Arm of CG about Datum		0.333	
Effect of reducing pilot weight by 10 kg	-10.0	-0.520	5.20
Effect of adding 3 kg trim ballast	3.0	-1.740	-5.22
New Weight and Moment	428.9		145.11
New Arm of CG about Datum		0.338	

Add the items in the Weight column to get the new total. Likewise add the Moments column. The new Arm = New Moment / New Weight.

Although the Moments about the datum are almost identical, the CG moves aft by 5mm.

10.4 Worked example 2: The aircraft is trimmed to optimum balance for a pilot of 90 kg. A pilot that is 20 kg heavier wants to fly the glider, but have the CG stay in exactly the same place. What weight must be placed in the fin battery compartment when this pilot flies to achieve this?

Working: The addition of the fin weight will affect both the total Weight and total Moment. This calculation is best done by iteration (trying different values until the desired result is achieved) on a spreadsheet as follows:

<i>tail-down is positive for Arm, Moment</i>	<b>WEIGHT</b>	<b>ARM</b>	<b>MOMENT</b>
	<b>kg</b>	<b>m</b>	<b>kg-m</b>
Total Weight and Moment	435.9		145.13
Arm of CG about Datum		0.333	
Effect of increasing pilot weight by 20 kg	20.0	-0.520	-10.40
Effect of adding tail ballast (iterate weight)	4.3	4.275	18.38
New Weight and Moment	460.2		153.11
New Arm of CG about Datum		0.333	

The result is that a weight of 4.3 kg attached at a distance of 4.275 metres aft of datum would achieve the required result.

10.5 Always take care when adding a significant amount of weight (say, more than 1.0kg) to the tail of a glider. If the calculations are incorrect the CG could easily be moved beyond the aft limit. It would be prudent to have another engineer check your calculations.